



AW-5600FX

Semi-Automatic Weigh-Wrap-Label System



PC Based

Standard Features

- User Friendly/Eye Catching 12.1" Color Display
- Remote Diagnostic Functions
- Audit Trail
- Date and Time Stamp
- Price Override Lock
- Password Protection
- Remote Update of Operating System, Label Formats, Preset Keys, Images
- Compatible with Third Party Scale Management Applications

Mandatory Regulations

- USDA Safe Handling Statement
- Cool (Country of Origin) Information
- Ingredients, Nutritional Information, Allergens, Trans Fats

Label Advertising Features

- Recipes
- Cooking Instructions
- Advertisement

Optional Features

LinerLess Labels Printer with World's First Auto-Cutter
Wireless Lan IEEE 802.11 a/b/g/n, Pop Labeler

*Searching for
a New Balance*

LinerLess Labels

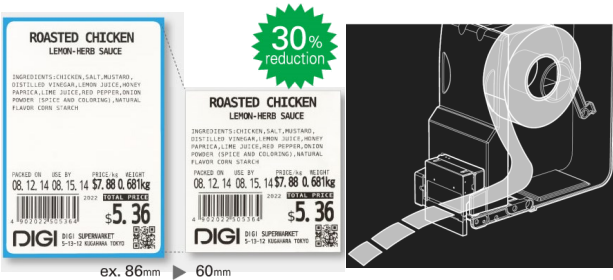

Increased Flexibility in Label Formats

The auto-cut feature cuts from a continuous strip of LinerLess labels every time a label is printed. Variable label layouts and sizes can be printed from a single roll.



Specifications

General	
Power Source	208/240V; 1Ø; 50/60Hz; 2.3kVA
Power Consumption	220-240V; 1Ø; 50/60Hz; 7.5A; 1.8kW
Dimensions	800 mm (W) x 935 mm (D) x 1428.5 mm (H) 31.5 in (W) x 36.8 in (D) x 56.24 in (H)
Net Weight	Approx. 250 kg/551 lb (Single Labeler Type)
Operation Humidity	90% RH (Max.) with No Condensation
Console	
Display Panel	TFT LCD Color (12.1 inches) Touch Panel
Operation Keys	Mechanical Keys and Touch Screen
Memory	8.8 GB
Printer	
Type	Thermal Printer
Dot Density	12 dot/mm (300 dpi)
Printing Width	40-80 mm (1.6-3.1 inches)
Printing Length	28-105 mm (1.1-4.1 inches)
Label Size	Width: 40-80 mm (1.6-3.1 inches) Length: 28-105 mm (1.1-4.1 inches)
Label Roll Diameter	Max. 210 mm (8.2 inches)
Label Roll Core Diameter	76 mm (3.0 inches)
Weighing	
Interval Type	Multi-Interval Single Interval
Capacity	Max. 6/15 kg Max. 3/6 kg Max. 30 lb
Scale Interval	e=2/5 g e=1/2 g e=0.01 lb
Weighing Range	40 g-15 kg 20 g-6 kg 0.20-30 lb
Max. Wrapping Capacity	5 kg 5 kg 11 lb
Wrapping	
Package Size	Width: 80-350 mm (3.1-13.8 inches) Height: 10-130 mm (0.4-5.1 inches) Depth: 80-230 mm (3.1-9.0 inches)
Wrapping Speed	Max. 17 packages/min
Number of Film Roll	One Roll
Film Width	350-500 mm (13.8-19.7 inches)
Film Length	Max. 1,500 m (4,900 feet)
Options	
Options	WLAN IEEE 802.11 a/b/g/n, Pop Labeler, LinerLess with Auto-Cutter

Operator Screen

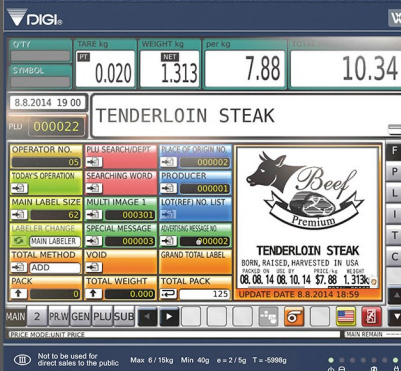

Trayless Products



Wrapper Dimensions

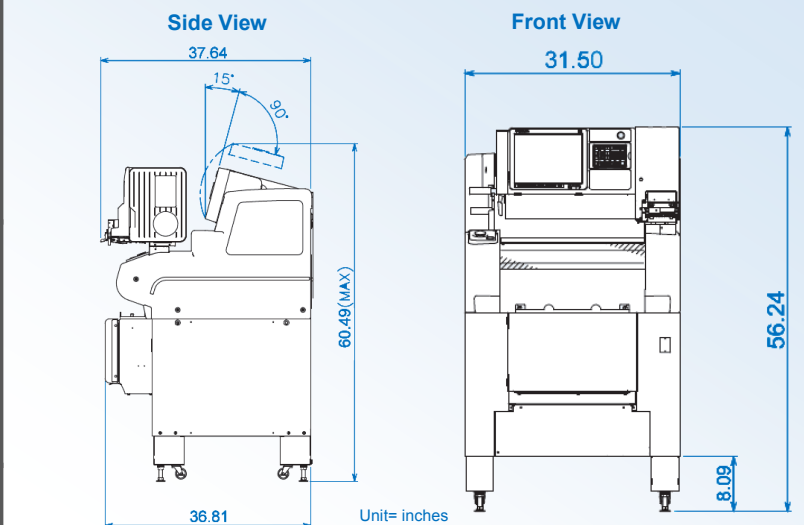

New Brunswick International, Inc.

A DIGI Group Company

Corporate Headquarters **West Coast Office**
 76 Veronica Ave 530 West Central Ave. Suite C
 Somerset, NJ 08873 Brea, CA 92821
 TEL: (732) 828-3633 TEL: (714) 671-7911
 FAX: (732) 828-4884 FAX: (714) 671-0798

www.nbidigi.com

Dealer